

THIS COPY IS PROVIDED ON A RESTRICTED BASIS AND IS NOT TO BE USED IN ANY WAY DETRIMENTAL TO THE INTERESTS OF PANDUIT CORP.

Material	High Conductivity Seamless Copper Tube
Plating	Electro-Tin
Wire Size	500 STR/FLEX
Wire Type	Stranded Copper: Class G, H, I, K, M, Locomotive
Wire Strip Length	1-9/16 in.
Stud Size	3/8 in.
UL Listed Wire Connector	Yes, for applications up to 35kv. Consult cable manufacturer for voltage stress relief instructions with applications greater than 2000 volts.
UL Temperature Rating	90° C
C.S.A Certified Wire Connector	Yes
Panduit Color Code on Barrel	PINK
Panduit Die Index No. on Barrel	P99
Alternate Industry Die Index No. ( ) on Barrel	(L99)

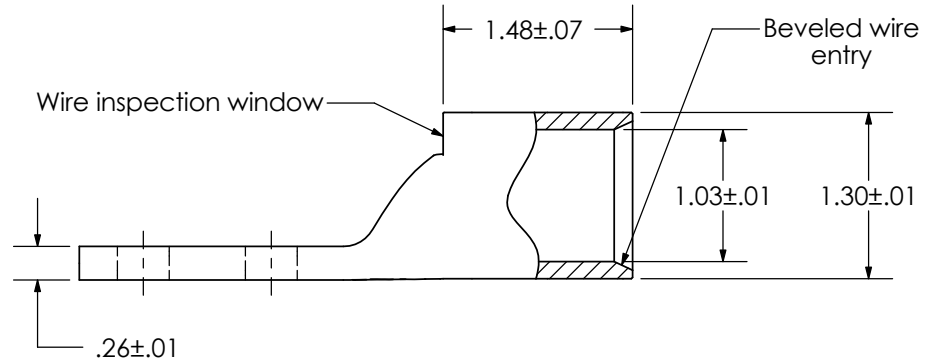
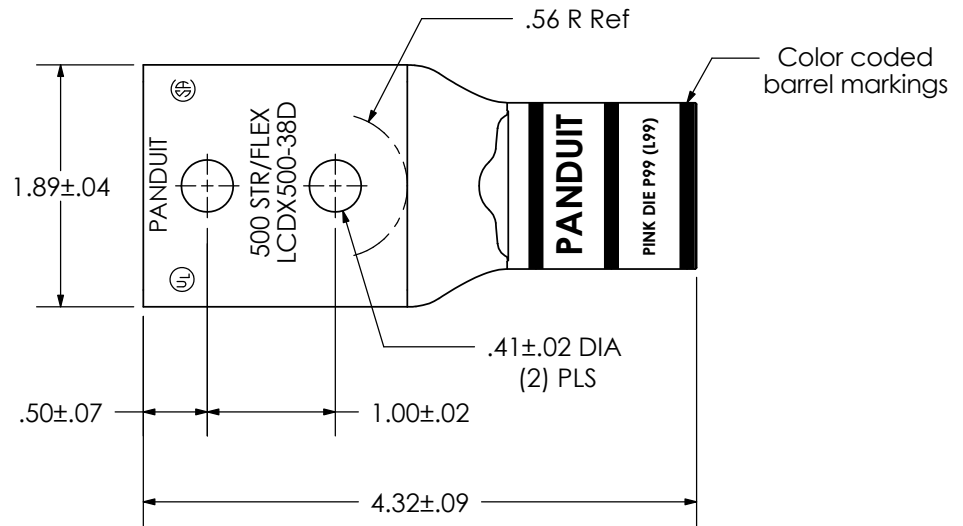

REV	DATE	BY	CHK	DESCRIPTION	ECN	SCALE	DRAWING NO / CAD FILE
01	4/09	JHNU	JHNU	REVISED TOLERANCES: HOLE OFFSET WAS .04, BARREL LENGTH WAS .04 OVERALL LENGTH WAS .06		N/A	LCDX500-38D-CUST

**PANDUIT CORP. TINLEY PARK, ILLINOIS**

LCDX500-38D-6  
Copper Lug - Two-Hole, Standard Flex Barrel